

12
SLOPE 3
MIN.

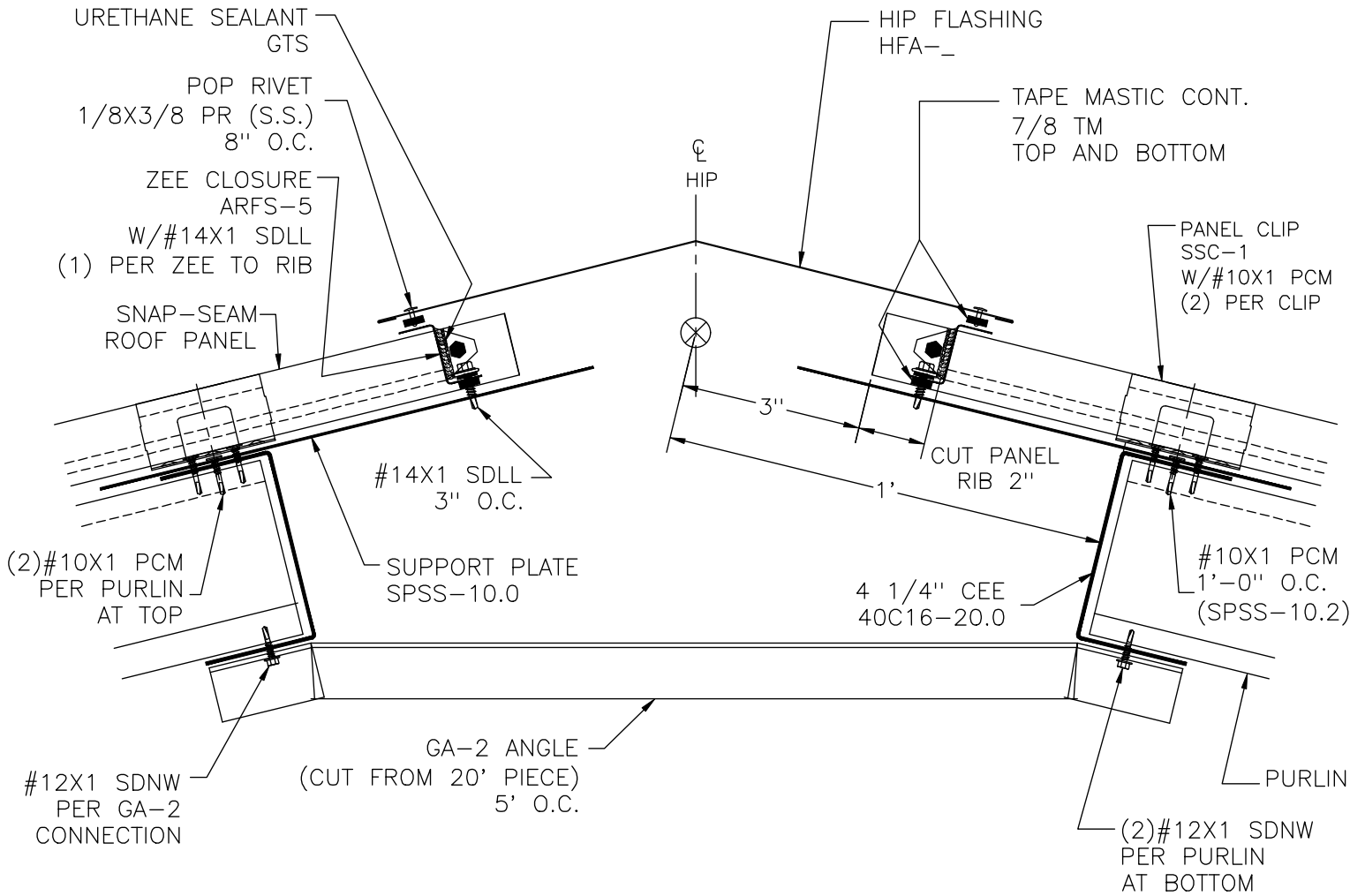

STANDARD HIP ON FRAMING
FOR SNAP-SEAM PANELS WITH ZEE CLOSURE

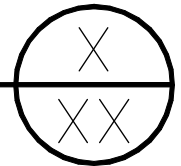

SCALE: NONE

DATE:

DRAWN BY: DC

04/28/08

CHECKED BY:

REVISED BY: KP

02/13/09

SNAP-SEAM STANDARD HIP
W/ZEE CLOSURE
ON FRAMING

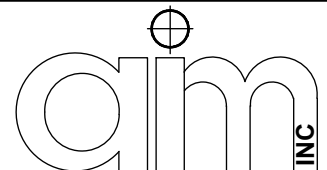

DWG NO:

SS.7.A.1