

SECTION THROUGH PANEL CLIP INSTALLATION

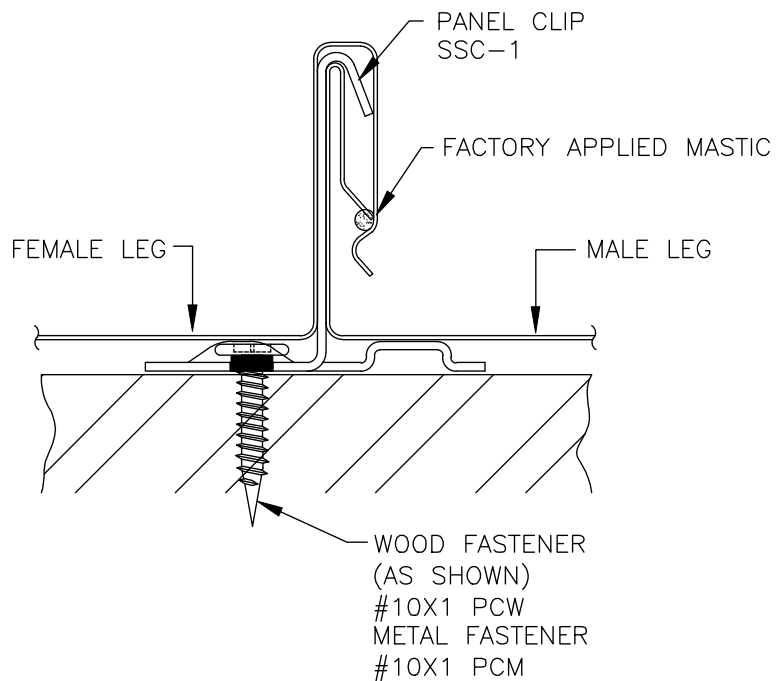

SECTION THROUGH PANEL AT CLIP

NOTE:
 CLIP SPACING SHOULD NEVER EXCEED 3'-0" O.C. FOR ATTACHMENT TO WOOD SUBSTRATE. PLYWOOD MUST BE MINIMUM 5/8".
 CLIP SPACING SHOULD NEVER EXCEED 4'-0" O.C. FOR ATTACHMENT TO 22 GAUGE METAL DECKING.

SCALE: NONE

DATE:

DRAWN BY: EC

7/7/04

CHECKED BY:

REVISED BY :

SNAP-SEAM PANEL CLIP
 AT SIDELAP DETAIL



DWG NO:

SS.9.A.4